

*Lightweight & excellent traction*  
**HELLIOS III**



3000



*Lightweight & excellent traction*  
**HELLIOS III**

3000



**A combination of low weight and excellent traction**

The HARDI HELLIOS III sprayers are compact and versatile. The machines are very easy to handle and offer outstanding ergonomics.

The machines feature a 3000 l main tank and aluminium booms of up to 30 m width and are thus a very cost efficient solution for treating small to medium sized plots.

The HELLIOS III is the lightest sprayer in its category: With an unladen weight of 7.2 t only combined with a 170 HP motorization and

a unique transmission concept, the HELLIOS III allows early season operations as it will easily work on soft soils. The HELLIOS III is one of the most fuel efficient sprayers of its kind.

The HELLIOS III cabin provides a modern and safe working environment to the operator with excellent visibility on the front boom and easy survey of the spraying operations. A pneumatic seat with numerous adjustment possibilities offers great comfort for your long working days.



### Lightweight

Hills, wet ground, slopes, etc.  
The HELLIOS III goes everywhere!



### Driving comfort: Three point suspension

The HELLIOS III features a pneumatic three point suspension on its chassis:

- ▶ 1 double layered air bellow on the front axle
- ▶ 2 triple layered air bellows on the rear axle



### Advantages of a hydromechanic transmission:

- ▶ More torque for better traction in hard conditions
- ▶ Less fuel consumption
- ▶ More cab comfort thanks to a silent environment
- ▶ Enhanced safety due to braked motors on the front wheels



**The combination of a cab with panoramic visibility and a front boom: Perfect visibility and control over your work.**

### SPECIFICATIONS

- ▶ **Tank:** 3000 l
- ▶ **Controller:** HC 8600 or HC 9600 (optional)
- ▶ **Graduated induction hopper:** 35 l capacity
- ▶ **Aluminium front booms:** from 21 to 30 m
- ▶ **Wide track width:** (280 or 270 cm) – for use on row crops
- ▶ **Engine:** Perkins Phase IV Final standard 125 kW / 170 HP
- ▶ **Cab:** Category 4 rated

- ▶ Driving comfort: Efficient suspension
- ▶ Lightweight: Hills, wet ground, slopes, etc. The HELLIOS III goes everywhere!
- ▶ Four-wheel steering for excellent manoeuvrability
- ▶ Engine: adequate power for high performance, economical sprayer
- ▶ Category 4 cabin: Optimum driver protection by delivering best possible air quality.

# Engine & Transmission

Adequate power for high performance and maximum fuel efficiency



### 170 hp engine

Unlike other machinery for crop protection, the HARDI sprayers come with enough balanced engine power to ensure excellent traction. The hydromechanical transmission and the low unladen weight are among the core advantages of the HELLIOS III:

- ▶ The ability to work efficiently (with traction, power and reactivity) without requiring an oversized engine.

### Easy maintenance

#### Engine compartment at the rear of the machine:

- ▶ Filters at working height for easier servicing
- ▶ Soundproof covers for reduced noise in the cab

#### Rear door:

- ▶ 250 litre fuel tank
- ▶ Storage space for personal protective equipment

### Hills, wet ground, slopes, etc. The HELLIOS III goes everywhere!

The HELLIOS III self-propelled sprayers feature:

- ▶ Hydromechanical transmission on the rear axle (see below)
- ▶ Hydraulic assistance on front wheels.

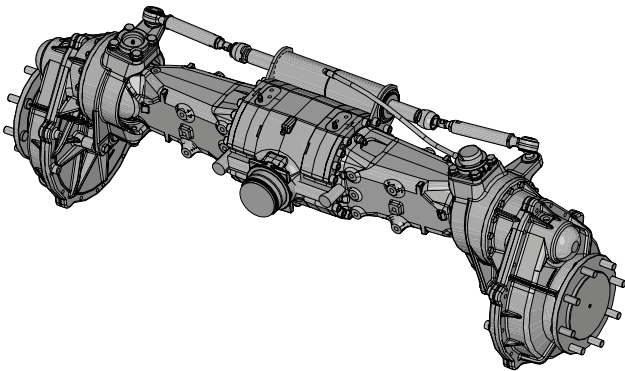

### Advantages of a hydromechanical transmission

You will easily cross difficult areas (hills, wet terrain, slopes, etc.)

- ▶ Improved drive efficiency: more torque to the ground
- ▶ No power loss
- ▶ Less weight compared to conventional hydraulic drives
- ▶ Better fuel economy

### Four-wheel steering for excellent manoeuvrability

Thanks to its four-wheel steering system, the HELLIOS III provides:

- ▶ Unparalleled traction and manoeuvrability:
  - ▶ *Slope mode for the rear-wheel steering: engage the crab mode to safely operate on cross slopes*
  - ▶ *Four wheel steering function for minimum turning radius*
- ▶ Preserving crops and soil
  - ▶ *In 4 wheel and crab steer mode the wheels follow the same track*

### Easy to use

The system is fully automated: no action is required to control the engine speed

### User friendly working environment

The nominal engine speed is at 1500 rpm, thus ensuring a silent working environment

### Fuel economy

The engine speed automatically adapts to the torque requirement for reduced fuel consumption

### Cruise Control

You drive at a steady speed, spraying uniformly and precisely metre after metre

### Automatic engine management:

Savings and comfort – guaranteed!

On the road	EcoControl	Automatic engine governor set for 1500 rpm
	Automotive	Automatic gear change (continuously variable transmission)
In the field	EcoControl	Automatic engine governor set for 1500 rpm
	Automotive	Cruise control





# Cab

## CATEGORY 4 PROTECTION

### The ideal cab for crop spraying!

- ▶ Optimum driver protection
- ▶ Higher air quality
- ▶ Excellent comfort

### Real driving comfort

Effective ventilation and air-conditioning

- ▶ Continuous air renewal to ensure a safe and healthy working environment
- ▶ Quick and effective demisting

### Optimum driver protection – The best possible air quality!

#### A high performance filtration system (to EN 15695-2 standard):

- ▶ Triple air filtration: paper, particles, active charcoal
- ▶ Ensures the best possible protection against exposure to dust, aerosols and vapours

#### A pressurised cab (to EN 15695-1 standard):

- ▶ No products can enter the cab thanks to the 20 Pa pressurisation
- ▶ A warning signal will come up should a loss of pressure be detected
- ▶ An additional 'Plus': our Category 4 cabs automatically pressurize as soon as the door is closed and the ignition is switched on. The driver does not need to take specific action to start the cab protection.

## Modern and Comfortable Working environment in the Cab



### Cab interior: more comfort and technology!

- ▶ A comfortable seat
- ▶ Armrest with ergonomic controls
- ▶ A cab fully equipped with ISOBUS technology
- ▶ Ergonomic cab access

### The HC 8600 controller

The complete integration of all important information on one work screen is a highly demanded criterion for most farmers.

The HC 8600 and HC 9600 (optional) have multicolour HD touch screens that are very easy to operate while providing an optimal overview for maximum control of the spray job.

### ZOOM ON THE ISOBUS TECHNOLOGY

- ▶ Our embedded technology is matching the ISOBUS standard requirements. If you are equipped with a MÜLLER ELEKTRONIK\*, TOPCON\*, TRIMBLE\*, JOHN DEERE\*, or AG LEADER\* guiding system, section control or variable rate, you can install your console instead of the existing terminal.

*\*) List of compatible models to be checked with your distributor*

# Aluminium front booms

– lightweight and rock solid!



## Advantages of aluminium booms:

- ▶ Resistance to corrosion, even after years of liquid fertiliser applications
- ▶ Robust
- ▶ Lightweight
- ▶ Zero paintwork maintenance
- ▶ Great stability

## Advantages of front booms:

- ▶ Comfortable working position
- ▶ Perfect and simple spray control
- ▶ Safety
- ▶ Easy manoeuvring
- ▶ Easy headland treatment

## A wide choice of booms

Width	Sections	Nozzles per section	Boom width, with outer sections folded	Section cut off when folded
21 m	6	5-8-8-8-8-5	17m	-
24 m	6	8-8-8-8-8-8	17 m	-
28 m	7	8-8-8-8-8-8-8	17 m	-
28/24 m	7	8-8-8-8-8-8-8	17 m	-
28/27 m	7	8-8-8-8-8-8-8	17 m	-
30 m	5	12-12-12-12-12	17 m	-
30 m	6	10-10-10-10-10-10	17 m	-
30 m	7	7-7-10-12-10-7-7	17 m	✓
30 m	8	6-8-8-8-8-8-8-6	17 m	✓
30/28 m	5	12-12-12-12-12	17 m	-
30/28 m	6	10-10-10-10-10-10	17 m	-
30/28 m	7	10-8-8-8-8-8-10	17 m	-

✓ The sections match to the width of the inner boom, you can thus spray on respectively 17, 19, or 20 m width depending on the total boom width.



## M-Select

The M-Select is a system combining a set of 4 nozzles. This system will automatically select the right combination of nozzles to match the dose set point.

- ▶ In case of a variable rate application, the combination of nozzles allows to spray the rate recommended by the application map (without any speed change).
- ▶ Even with significant working speed variations, the applied dose is constant (l/ha) and the droplet size stays uniform.
- ▶ The M-Select optimizes the amount of product sprayed with a better application.
- ▶ At work, dose setpoint and pressure will be maintained whichever the speed.

# Continuous mixture circulation:

Ask for HARIDs PPI®!

**The PPI® CIRCULATION is a standard on HELLIOS III:**

- ▶ No mixture reflow during spraying
- ▶ Immediate section opening / cut off
- ▶ No additional mixture return pipe on the boom
- ▶ Mixture circulation when spraying circuit is closed for immediate pressure when starting the spraying job

**Why is HARIDs PPI® CIRCULATION system unique?**

Unlike other sprayers fitted with mixture reflow systems, the HELLIOS III PPI® CIRCULATION comes with only a short single return pipe (no return pipe from the boom).

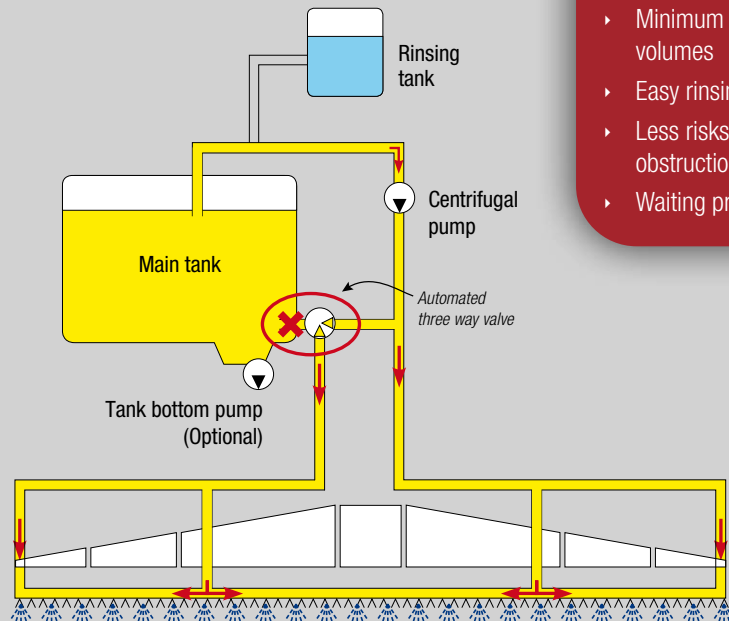

## The advantages

- ▶ Reactivity
- ▶ Precision
- ▶ Minimum residual volumes
- ▶ Easy rinsing
- ▶ Less risks of obstruction
- ▶ Waiting pressure

## Technical specifications

Main tank	3000 l
Rinsing tank	300 l
Fuel tank	250 l
Min.-Max. track width	1,80 to 2,80 m
Overall width	2,55 m
Turning radius	3,60 m
Unladen weight	7.2 t
Front/Rear weight distribution	45 % / 55 % (folded boom) 40 % / 60 % (unfolded boom)

Weight indication for HELLIOS III 3000 l – 28 m.

3.86 m  
Heights  
depending  
on tires and  
boom width



Standard ground  
clearance 1,10 m



6,76 m  
6,80 m - 9,13 m

### MOTORIZED VALVES (optional)

- ▶ Manage the suction and pressure valves at your fingertips, and without leaving your seat.
- ▶ Simplify your field operations
- ▶ Complete the main tank with clear water
- ▶ Rinse the boom and the tank while staying in the cab
- ▶ Simple and intuitive control box in the cab and at the filling station.



### Pentajet nozzleholders with integrated LED (Optional)



### HARDI INTERNATIONAL A/S

With over 60 years' experience behind us, HARDI INTERNATIONAL A/S remains a global trendsetter for application of crop protection products. Headquartered in Denmark, we are present in more than 100 countries through a network of subsidiaries, agents and importers.

HARDI INTERNATIONAL A/S is known for the quality, design and performance of our machines. By always putting the customer at the centre of our innovative solutions, we strive to shape the future in plant protection. Our increasingly intelligent products are capable of delivering exact doses and targeted applications with minimal drift and waste – to the benefit of the farmer and the environment.

We believe in a future where our products will be able to take care of plants one by one.



#HARDIsprayers



## HARDI INTERNATIONAL A/S

Herthadalvej 10 · 4840 Nørre Alslev · Denmark · Tlf.: +45 54 46 48 00 · Fax: +45 54 46 48 12  
 E-mail: [hardi@hardi-international.com](mailto:hardi@hardi-international.com) · [www.hardi-international.com](http://www.hardi-international.com)